

Approved Materials List for Water Distribution Potable System Materials Testing and Inclusion Procedures

Manufacturers who would like materials considered for the approved materials list shall:

1. Comply with all the design criteria set forth for the approved materials.
2. Supply, at the manufacturer's expense, the materials to be tested. (Quantity to be determined by the Nibley City Public Works Department)
3. Any project using brass or bronze service material that comes in contact with potable water must meet AWWA C-800, NSF 61-8 and Federal Law.
4. Preference will be given to materials manufactured and assembled in the United States.

Once the materials have been received, the Water Division will visually inspect materials for defects and compliance with all City standards. The Water Division will install or oversee the installation of all materials in the distribution system or other test sites as determined to be in the best interest of the City. Materials will be tested and evaluated for a minimum of one year, commencing on the date of installation. Evaluations will include but are not limited to:

1. Ease of installation
2. Availability of parts
3. Operational issues
4. Quality of manufactured materials
5. Number of moving parts
6. Reliability of service

If the materials supplied, at any time in the testing period fail, the testing will be concluded immediately. If the materials successfully complete the testing period, Water Distribution will recommend the product to be included in the Nibley City Approved Materials List.

The Approved Materials List will be updated at least annually at the first of each year. Except for emergencies, new Manufacturers and Models that have been approved by the City for inclusion on the list will be added at that time.

A maximum number of manufacturers will be approved for each category. Once a category has been satisfied, manufacturers successfully completing the test requirements will be added to a waiting list. Pending materials will be listed sequentially according to successful completion of testing. Materials presently on the Approved Materials List may be omitted from the list due to:

1. Change in service/availability.
2. Change in product design.
3. Bankruptcy
4. Consistent product failure
5. Other issues that found to reasonably be cause for omission as determined by the City Engineer.

If an approved material is taken off the list for any of the above reasons, the first pending material will be added to the list.

Nibley City Engineering Design Standards

Approved Materials List for Water

Record of Changes- April 2024

MATERIAL	ACTION	DATE
Gate Valves	Updated pressure class rating	4/10/2024
Water Service Saddles	Eliminated manufacturer model numbers and added material descriptor	4/10/2024
Tapping Sleeves	Expanded the list of allowable manufacturers	4/10/2024
Water Meter Barrel frame and lid	Updated 2-inch water meter frame and lid	4/10/2024
Water Meter Setter	Removed angled dual check valve on 2-inch setter	4/10/2024
Water Meter Setter	Updated model number of Mueller 2-inch setter	4/10/2024
2-inch Water Meter Barrel	Updated 2-inch Water Meter Barrel to 30-inch diameter	4/22/2024

 Tom Dickinson, PE
 City Engineer, Nibley City

4/22/2024

 Date

Water Distribution Materials

Fire Hydrants (3 Manufacturers)

Requirements

- Meet APWA and AWWA Standard C502 and C550
- UL 246 approved
- Dry barrel hydrant
- Working Pressure rating of 250 psi
- Method of lubrication shall be food grade oil or grease
- Operating nut shall be 1-1/2 inches pentagon (standard)
- Direction of opening shall be counterclockwise (left)
- Hose and pumper threads (male) shall be brass and field replaceable
- Threads shall be "National Standard"
- 2 hose nozzles (2-1/2 inches) and 1 pumper nozzle (4-1/2 inches)
- Inlet connection shall be mechanical joint
- Shall include "traffic flange"
- Hydrant laterals shall be PVC DR14 material with mechanically restrained joints
- A 2.0 to 3.0 square foot concrete thrust block shall be installed at the base of all hydrants
- Size of hydrant valve opening shall be 5-1/4 inches
- All public hydrants shall be painted red



MANUFACTURER	MODEL
East Jordan (EJ) - Preferred	Watermaster 5CD 250
Clow	Medallion
Mueller	Super Centurion 250

Blow Off/Flushing Hydrants (1 Manufacturer)

Requirements

- Flushing Valves are used on dead end lines for flushing purposes where fire flows are not adequate
- Shall be provided with a 4-inch gate valve accessible and near the flushing hydrant
- Working Pressure rating of 250 psi
- 2 Nozzle Bolted Flange Top Stock
- Location to be approved by City Engineer
- Protected from damage and traffic by bollards or other
- Must have MJ Inlet sized for 3 fps flushing of main line
-



2 NOZZLE BOLTED FLANGE TOP STOCK



MANUFACTURER	MODEL
Kupferle	Eclipse #2 Post Hydrant 2-nozzle Bolted Flange Top Stock

Water System Grease (2 Manufacturers)

Requirements

- All metal threaded parts used in the water system, including “Blue Bolts” shall be applied with food grade grease meeting NSF requirements.

<u>MANUFACTURER</u>	<u>MODEL</u>
Mystik	FG-2 Food Machinery Grease
Clarion	Food Machinery Grease



Fire Hydrant Locks (2 Manufacturers)

Requirements

- Must prevent unauthorized operating of hydrants
- Readily attaches to all hydrant makes and models
- Must be strong enough to withstand vandalism and weather extremes
- Hydrant must be operated without removal of lock utilizing magnetic type wrench only

<u>MANUFACTURER</u>	<u>MODEL</u>
Hydra-Shield	Custodian
USA Blue Book	Hydrant Lok



Gate Valves (4 Manufacturers)

Requirements

- Meet APWA and AWWA Standards C515 and C550
- Valves body shall be epoxy coated ductile iron and meet or exceed reduced wall standards
- Valve wedge shall be fully encapsulated with nitrile rubber
- Valves shall be epoxy-coated inside and out
- Working Pressure rating of 250 psi
- Stem o-rings shall be replaceable with the valve fully open at rated working pressure
- Direction of open shall be counterclockwise (left)
- All fasteners shall be stainless steel

<u>MANUFACTURER</u>	<u>MODEL</u>
Mueller	Series 2361 or 2362
Clow	Style 2638 or 2639
Kennedy	Style 7000
M&H	Style 7000



Air/Vacuum Release Valves (1 Manufacturer)

Requirements

- Air/vacuum release valves shall be constructed of composite or stainless-steel components
- Parts and fittings for Air/Vacuum Release Valves shall be of Stainless-Steel construction.

<u>MANUFACTURER</u>	<u>MODEL</u>
ARI	No. D-060NT – Combination air valve “Barak” w/ 1-1/2” x 2” ARI Bug Screen



Butterfly Valves (1 Manufacturer)

Requirements

- Butterfly valves are required on distribution mains 12 inches and larger.
- Meet applicable APWA and AWWA Standards C504 Standard
- Valves shall be 250 class pressure rated or higher
- The valve disc shall be fully encapsulated in nitrile rubber
- Valves shall be epoxy coated inside and out
- All fasteners shall be stainless steel
- Direction of open shall be counterclockwise (left)

<u>MANUFACTURER</u>	<u>MODEL</u>
Crispin	K-FLO

No exceptions



Pressure Reducing, Sustaining and Altitude Valves (1 Manufacturer)

Requirements

- Ductile iron body
- Diaphragm type, class 150
- Epoxy coated inside and out
- Stainless steel parts and fittings
- Tested at a minimum pressure of 175 psi
- 150 lb flanged ends

<u>MANUFACTURER</u>	<u>MODEL</u>
CLA-VAL	No. 92-01, 50-01, and 650-01



Water Meters (1 Manufacturer)

Requirements

- Appropriate make, model, and manufacturer is to be determined by the Water Distribution Department. All meters are supplied by Water Distribution.

<u>SIZE</u>	<u>TYPE</u>	<u>MANUFACTURER</u>
1"	Magnetic / Positive Displacement	Neptune
2"	Magnetic / Positive Displacement	Neptune
4" to 6"	Magnetic	Neptune
8" and Larger	Per City Engineer's Direction	Neptune
Fire Hydrant Meter	3"	City Provided



Radio Read Meter Reading Devices (1 Manufacturer)

<u>MANUFACTURER</u>	<u>MODEL</u>
Neptune	E-coder R900i



Water Service Saddles (5 Manufacturers)

Requirements

- Meet applicable APWA, AWWA C800, and NSF 61 Standards
- Double strap brass or stainless-steel
- Saddle- brass or stainless-steel
- Thread shall be female iron pipe

<u>MANUFACTURER</u>	<u>MODEL</u>
Ford	Any model made of the materials noted above
AY McDonald	
Mueller/Jones	
PowerSeal	
Romac	



Water Mains (All Manufacturers)

Requirements

- All mains shall be Blue PVC per AWWA C-900 or C-905 for larger pipe
- Meet ASTM Standard D3139 & F477; UL 157
- C-900- Minimum class DR 14 (305 psi)
- C-905- Minimum class DR 18 (235 psi) (14-inch diameter and larger)



Water Service Lines

Requirements

- Minimum size service line is 1"
- ASTM 2737
- 250 psi minimum pressure rating (SDR 9)
- AWWA C901 – 1" to 2"; AWWA C900 – 4-inch and larger
- Diameter of service line material must be to the nearest inch in size – no half inch increment pipe
- Water service lines shall be the same size as the water meter from the connection at the water main to the meter. Exception for manifolded meters for 4-unit residential structures- see Design Standards.



Corporation Stops (3 Manufacturers)

Requirements

- Meet applicable AWWA C800 and NSF 61 Standards
- Inlet threads shall be iron pipe
- Shall utilize a ball valve
- For service line installations, the outlet shall utilize a compression style pack joint
- For downstream end of blow off installations, the outlet shall utilize male iron pipe threads



MANUFACTURER	MODEL
Ford	FBRW1100-TA
AY McDonald	4104B-22
Mueller/Jones	P25028-10/E-1935

Backflow and Cross-Connection Devices

Requirements

- Refer to the approved assemblies list published by the USC Foundation for Cross-Connection Control and Hydraulic Research for backflow prevention and cross-connection devices and assemblies that are approved for use in the City.

Meter Valves/Curb Stops (3 Manufacturers)

Requirements

- Meet applicable AWWA C800 and NSF 61 Standards
- Angle stop ball valve with 90-degree Tee Head rotation
- Padlock wings
- The inlet shall utilize a compression style pack joint with set screw
- 1" curb stops shall have a swivel meter coupling to allow for meter installation
- 2" curb stops shall be flanged, have elongated bolt holes allowing for either 2" and 1 1/2" meters, and allow for drop in rubber gaskets



<u>MANUFACTURER</u>	<u>MODEL</u>
Ford	BFA43-777W, BA43-444W
AY McDonald	4602B-22
Mueller/Jones	P-24258, P-24276/E-1963, E-1975

Tapping Sleeves (2 Manufacturers)

Requirements

- Meet AWWA C223-02
- No Size on size applications
- All stainless-steel sleeve and saddle
- Blue bolts allowed



<u>MANUFACTURER</u>	<u>MODEL</u>
Powerseal	Any model made of the materials listed above
Smith Blair	
Ford	
AY McDonald	
Mueller	

Full Circle Repair Clamps (3 Manufacturers)

<u>MANUFACTURER</u>	<u>MODEL</u>
Romac	SS1, SL1
Ford (Single Band)	F1
Smith-Blair	221, 226, 229, 238



Flex Couplings (3 Manufacturers)

<u>MANUFACTURER</u>	<u>MODEL</u>
Romac	XR-501 Extended Range
Ford	FC2W Transition Coupling
Total Piping Solutions	HyMax 2 Series



Restrained Flange Coupling Adapters (3 Manufacturers)

<u>MANUFACTURER</u>	<u>MODEL</u>
Smith-Blair	912
Romac	FC400/FCA 501/RFCA
Ford	FFCA



Restrained Joints - Gasket Style (4 Manufacturers)

<u>MANUFACTURER</u>	<u>MODEL</u>
American Cast Iron Pipe Co.	Flex Ring Joint
American Pipe	Fast Grip Gasket
McWane	Sure Stop 350 Gasket
Griffin Pipe	Talon Gasket



Restrained Joints - Mechanical Style (5 Manufacturers)

Requirements

- Meet applicable AWWA Standards
- Must be approved for the pipe material

<u>MANUFACTURER</u>	<u>MODEL</u>	<u>Pipe Material</u>
EBBA Iron	1100 Series	Ductile Iron and Steel
Romac	Roma Grip	Ductile Iron and steel
Ford	UFR 1400	Ductile Iron
Star Pipe Products	Stargrip Series 3000	Ductile Iron
Star Pipe Products	Stargrip Series 4000	PVC
Star Pipe Products	Pipe Restrainers Series 1100G2	PVC
Romac	Grip Ring	Ductile Iron and PVC



Water Meter Barrels / Pits

Requirements

- 21" diameter for 1" meters; 30" diameter for 2" meters
- HDPE smooth single wall or Corrugated dual wall HDPE
- 3" wide by 3.25" tall notch at 0 and 180 degrees
- 48" length



Water Meter Barrel Covers

Requirements

- Lid Diameter: 1" Meter - 12"; 2" meters 31 1/2"
- Overall Diameter: 1" Meter - 23"; 2" meters 39 1/8"
- Recessed for Neptune antenna

METER SIZE	MANUFACTURER	MODEL
1"	D&L	L-2244
2"	D&L	A-1180-101*

*2-inch frame- D&L 1180-R3

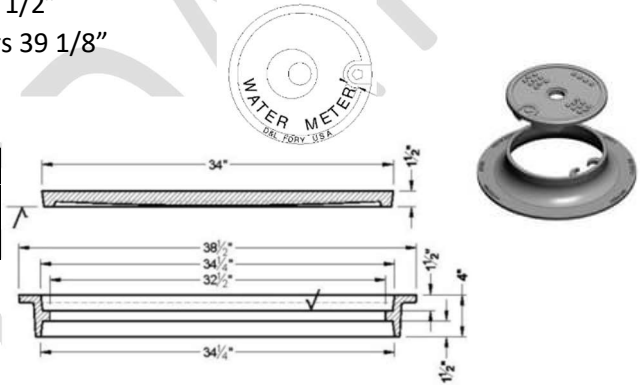

Water Line Fittings

Requirements

- Ductile Iron
- Flanged
- Blue Bolts
 - Fluoropolymer Coating
 - Corrosion-resistant, high-strength low-alloy steel
 - ANSI/AWWA C111/A21.11



Water Meter Setter (3 Manufacturers)

Requirements

- For 1" and 2" meters
- 18" setter length
- Copper tubing
- Lead free
- Padlock wings
- Angle key Valve on City side
- Brass components ASTM B584 & NL (in contact);
ASTMB62 & B584 (non contact)
- Angle dual check valve on customer side
- Compression fittings at City and customer connections
- The shut off valve of each setter shall measure 24 to 30 inches below the finished elevation of meter lid.
- 18" long - ¾" schedule 40 PVC pipe installed through hole in the bottom of each 1-inch setter
- 18" long- 1" schedule 40 PVC pipe installed through hole in the bottom of each 2-inch setter
- Tracer wire to be accessible and installed with sufficient length to extend to the top of the meter barrel or vault
- Setters for 4 and 6 inch meters shall be in accordance with APWA Standards as amended by Nibley City.

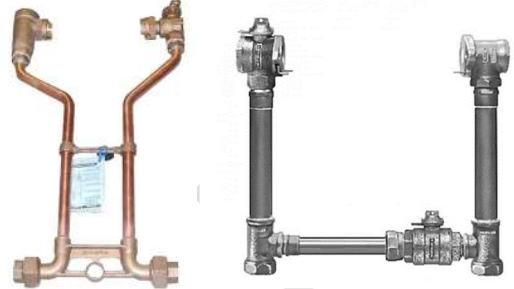

<u>METER SIZE</u>	<u>MANUFACTURER</u>	<u>MODEL</u>
1"	AY McDonald	720-418CDD44
1"	Ford	VH-74-18W-11-44-NL
1"	Muller	H-14195-6DN
2"	AY McDonald	721-718WDGG77
2"	Ford	VBHH-77-18B-44-77-NL
2"	Muller	B-2427-2N

Valve Boxes (3 Manufacturers)

Requirements

- Top and Bottoms to be domestic
- Slip cover
- 24-pound universal lid required in all arterial streets
- Installed per amended APWA standards with concrete collar

<u>MANUFACTURER</u>	<u>MODEL</u>
Tyler Union	6855/145325/145451
Bingham & Taylor	GRE-5B64S/5T55SCL35/5LHVTSK4WCL35/CUL5LWRDBLACK
EJ Iron Works	6800/8555



Pipe Wrap Tape

Requirements

- 2" Wide
- 20 Mill Thickness
- Suitable for use between at 60° C
- Moisture resistant
- Adheres to metal and plastic
- Non-corrosive, pressure-sensitive adhesive
- Does not require heat, moisture, or other manner of preparation to apply



Polymer Pipe Wrap

Requirements

- 12 mil Polyethylene Material
- AWWA C-105



Tracer Wire

Requirements

- #12 solid AWG copper wire
- 2,500-foot minimum roll length
- Grease Connectors – 3M Direct Bury Kit DBR/Y-6, or Hughes Dri-Splice DS-100; DS-400; DS-500 or equal
- Splices shall be kept to a minimum



Buried Water Line Marking Tape

Requirements

- 3" minimum width
- 4 Mill minimum
- Blue in color
- Black lettering "BURIED WATERLINE"
- Placed a minimum of 36-inches above the water main or just below the pavement section (pit run for road) if less than 36-inches above the pipe.



Secondary Water Swing Connection

Requirements

- Must provide a full airgap disconnect between the two systems
- Must be documented by City Staff
- State of Utah requires a backflow prevention device between the connection and the City meter

